



Commercial
Water Filters

UF Series Twin Membrane System

Installation Instructions & Owner's Manual



Table of Contents

Pre-Installation Instructions for Dealers.....	3
Bypass Valve	4
Installation.....	5
Programming Procedures	7
Start-up Instructions.....	8
Operating Displays and Maintenance	9
Troubleshooting Guide	11
Replacement Parts	16
Installation Fitting Assemblies.....	24
Specifications.....	26
Warranty.....	27
Quick Reference Guide.....	28

YOUR WATER TEST

Hardness _____ gpg
Iron _____ ppm
pH _____ number
*Nitrates _____ ppm
Manganese _____ ppm
Sulfur _____ yes/no
Total Dissolved Solids _____

*Over 10 ppm may be harmful for human consumption.
Water conditioners do not remove nitrates or coliform bacteria,
this requires specialized equipment.

STARTUP DATA

Installation Date _____
Installation Dealer _____
Separate Source Reg. Kit Installed _____
Volume Between Flushing (gallons) _____
Time Between Regeneration (hrs) _____

Your A. O. Smith UF Filtration system is a precision built, high quality product. This unit will deliver quality water for many years to come, when installed and operated properly. Please study this manual carefully and understand the cautions and notes before installing and operation. This manual should be kept for future reference. If you have any questions regarding your system, contact your local dealer.

Pre-Installation Instructions

The manufacturer has preset the water treatment unit's sequence of cycles and cycle times.

THE DEALER SHOULD...

- Read this page and guide the installer regarding time of regeneration, service alarm, and programming settings prior to installation.

THE INSTALLER SHOULD...

- Program installer regarding time of regeneration, service alarm, and programming settings prior to installation.
- Read Operating Displays and Maintenance section.
- Set the time of day
- Read Power Loss and Error Display section.
- Ensure that system and installation are in compliance with all state and local laws and regulations
- Allow space for membrane removal

THE HOMEOWNER SHOULD...

- Read Programming Procedures section.
- Read Operating Displays and Maintenance section.

GENERAL OPERATING DISPLAYS & NAVIGATION

During normal operation, the default user displays are "time of day" and "gallons per minute". Flow rate, vacation mode, capacity remaining, and days to a regeneration are optional displays. For more explanation, consult the "operating displays and maintenance section". Pressing the **NEXT** button on a general operating screen will cycle through the available operating displays.

In any screen other than a general operating display, the **NEXT** button will proceed to the next step, the **REGEN** button will return to a previous step, and the **CLOCK** button will return to the general operating displays. Any changes made prior to the exit will be incorporated. If no buttons are pressed within five minutes, the display will return to the general operating displays.

ULTRA FILTRATION FLUSHING SCHEDULE

The UF Series Filter is factory preset to backwash every day at midnight. This is dependent on the quality of water being treated and may be adjusted by the installing dealer based on the water quality. A post ultra-filtration pressure tank may be installed to ensure a sufficient flow of water and pressure to the home during a flush cycle.

IMPORTANT: If a post pressure tank is used a check valve may be required to allow for treated water regeneration. In this case an expansion tank should be installed to account for thermal expansion. See drawing in the back of this manual.

Default Factory Setting

Standard Unit with or without Separate Source Regeneration (SSR)

Flush Frequency: Every Day

Backwash Flush Duration: 2 Min. at 5.3 GPM

Rinse Duration: 1 Min. @ 5.3 GPM

Bypass Valve

The bypass valve is typically used to isolate the control valve from the plumbing system's water pressure in order to perform control valve repairs or maintenance. The 1" full flow bypass valve incorporates four positions, including a diagnostic position that allows a service technician to have pressure to test a system while providing untreated bypass water to the building. Be sure to install bypass valve onto main control valve before beginning plumbing or make provisions in the plumbing system for a bypass. The bypass body and rotors are glass-filled Noryl® and the nuts and caps are glass-filled polypropylene. All seals are self-lubricating EPDM to help prevent valve seizing after long periods of non-use. Internal "O" Rings can easily be replaced if service is required.

The bypass consists of two interchangeable plug valves that are operated independently by red arrow shaped handles. The handles identify the direction of flow. The plug valves enable the bypass valve to operate in four positions.

- 1. NORMAL OPERATION POSITION:** The inlet and outlet handles point in the direction of flow indicated by the engraved arrows on the control valve. Water flows through the control valve for normal operation of a water softener or filter. During the regeneration cycle this position provides regeneration water to the unit, while also providing untreated water to the distribution system (**Fig. 1**).
- 2. BYPASS POSITION:** The inlet and outlet handles point to the center of the bypass. The system is isolated from the water pressure in the plumbing system. Untreated water is supplied to the building (**Fig. 2**).
- 3. DIAGNOSTIC POSITION:** The inlet handle points toward the control valve and the outlet handle points to the center of bypass valve. Untreated supply water is allowed to flow to the system and to the building, while not allowing water to exit from the system to the building (**Fig. 3**). This allows the service technician to test the unit and perform other functions without disrupting the water going to the building.

NOTE: The system must be rinsed before returning the bypass valve to the normal position.

- 4. SHUT OFF POSITION:** The inlet handle points to the center of the bypass valve and the outlet handle points away from the control valve. The water is shut off to the building. The water treatment system will depressurize upon opening a tap in the building. A negative pressure in the building combined with the unit being in regeneration could cause a siphoning to the building. If water is available on the outlet side of the unit, it is an indication of water bypassing the system (**Fig. 4**) (i.e. a plumbing cross-connection somewhere in the building).

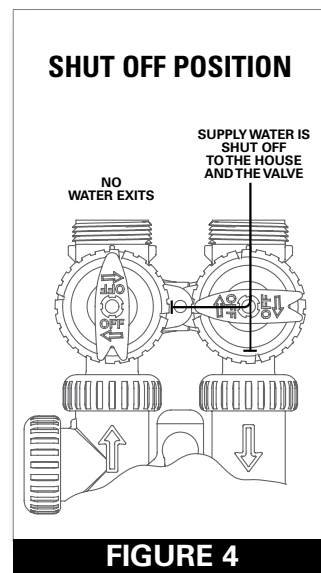
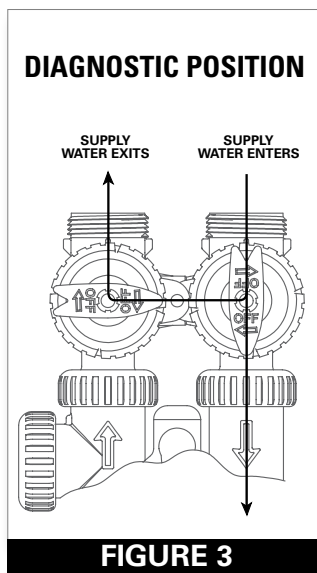
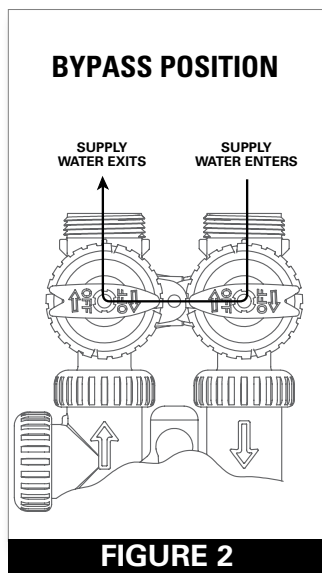
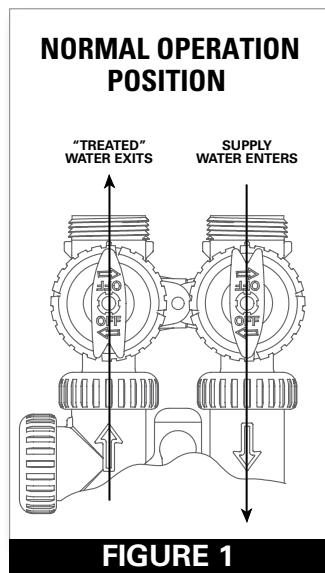

Installation

GENERAL INSTALLATION & SERVICE WARNINGS

The control valve, fittings and/or bypass are designed to accommodate minor plumbing misalignments. There is a small amount of “give” to properly connect the piping, but the water softener is not designed to support the weight of the plumbing.

Do not use Vaseline, oils, other hydrocarbon lubricants or spray silicone anywhere. A silicone lubricant may be used on black “O” Rings, but is not necessary. Avoid any type of lubricants, including silicone, on red or clear lip seals.

Do not use pipe dope or other sealants on threads. Teflon® tape must be used on the threads of the 1” NPT inlet and outlet and on the threads for the drain line connection. Teflon® tape is not used on the nut connections or caps because “O” Ring seals are used. The nuts and caps are designed to be unscrewed or tightened by hand or with the special plastic Service Wrench, #CV3193-02. If necessary pliers can be used to unscrew the nut or cap. Do not use a pipe wrench to tighten nuts or caps. Do not place screwdriver in slots on caps and/or tap with a hammer.

SITE REQUIREMENTS

- Water pressure – 30-100 psi
- Water temperature – 33-100°F (0.5-37.7°C)
- Electrical – 115/120V, 60Hz uninterrupted outlet
- Current draw is 0.5 amperes
- The plug-in transformer is for dry locations only

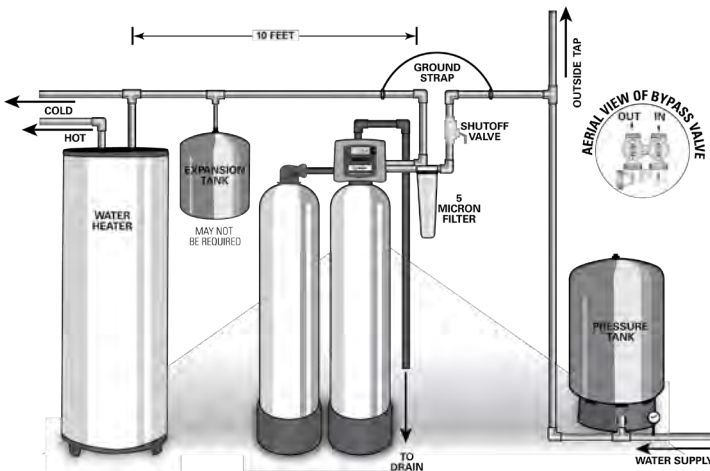

WELL WATER INSTALLATION

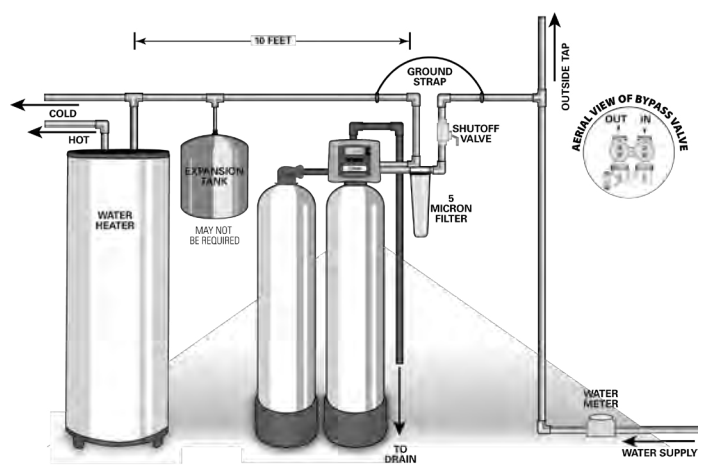

MUNICIPAL INSTALLATION

1. The distance between the drain and the water conditioner should be as short as possible (see step 8).
2. Do not install any water conditioner with less than 10 feet of piping between its outlet and the inlet of a water heater.
3. The media tank should be installed on a firm, level surface (above or below grade).
4. Do not locate unit where it or its connections (including the drain and overflow lines) will ever be subjected to room temperatures under 33°F.
5. Do not subject the tank to any vacuum, as this may cause an “implosion” and could result in leaking. If there is a possibility a vacuum could occur, please make provision for a vacuum breaker in the installation.

6. INLET/OUTLET PLUMBING: Be sure to install Bypass Valve onto main control valve before beginning plumbing. (See

installation picture to right. Be sure bypass is connected to treated water inlet and outlet.) Make provisions to bypass outside hydrant and cold hard water lines at this time. Install an inlet shutoff valve and plumb to the unit’s bypass valve inlet located at the right front as you face the unit. There are a variety of installation fittings available. They are listed under the Installation Fitting Assemblies section. When assembling the installation fitting package (inlet and outlet), connect the fitting to the plumbing system first and then attach the nut, split ring and “O” Ring. Heat from soldering or solvent cements may damage the nut, split ring or “O” Ring. Solder joints should be cool and solvent cements should

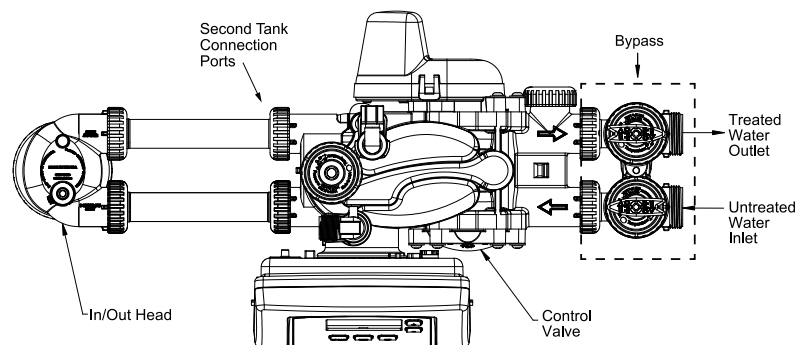

Installation

be set before installing the nut, split ring and "O" Ring. Avoid getting solder flux, primer, and solvent cement on any part of the "O" Rings, split rings, bypass valve or control valve. If the building's electrical system is grounded to the plumbing, install a copper grounding strap from the inlet to the outlet pipe. Plumbing must be done in accordance with all applicable local codes.

7. **INSTALLING GROUND:** To maintain an electrical ground in metal plumbing of a home's cold water piping (such as a copper plumbing system), install a ground clamp or jumper wiring.

NOTE: If replacing an existing filter, also replace the ground clamps/wire. If removing a filter, replace the piping with the same type of piping as the original to assure plumbing integrity and grounding.

8. **DRAIN LINE:** First, be sure that the drain can handle the backwash rate of the system. Solder joints near the drain must be done prior to connecting the drain line flow control fitting. Leave at least 6" between the drain line flow control fitting and solder joints. Failure to do this could cause interior damage to the flow control. Install a 1/2" I.D. flexible plastic tube to the Drain Line Assembly or discard the tubing nut and use the 3/4" NPT fitting for rigid pipe (recommended).

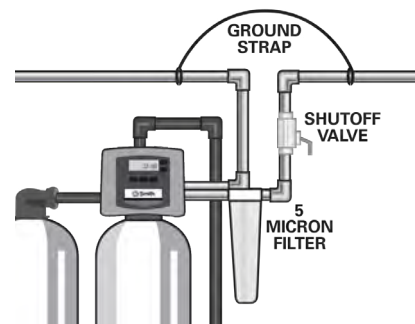

If the backwash rate is greater than 5.3 gpm, use a 3/4" rigid drain line. Where the drain line is elevated but empties into a drain below the level of the control valve, form a 7" loop at the discharge end of the line so that the bottom of the loop is level with the drain connection on the control valve. This will provide an adequate anti-siphon trap. Piping the drain line overhead <10 ft. is normally not a problem. Be sure adequate pressure is available (40-60 psi is recommended). Where the drain empties into an overhead sewer line, a sink-type trap must be used. Run drain tube to its discharge point in accordance with plumbing codes. Pay special attention to codes for air gaps and anti-siphon devices.

NOTE: Drain line nut will not be supplied for units having a backwash rate greater than 7 gpm.



CAUTION: Never insert a drain line into a drain, sewer line, or trap. Always allow an air gap of 1-1/2" or twice the pipe diameter, whichever is greater, between the drain line and the wastewater to prevent the possibility of sewage being back-siphoned into the softener.

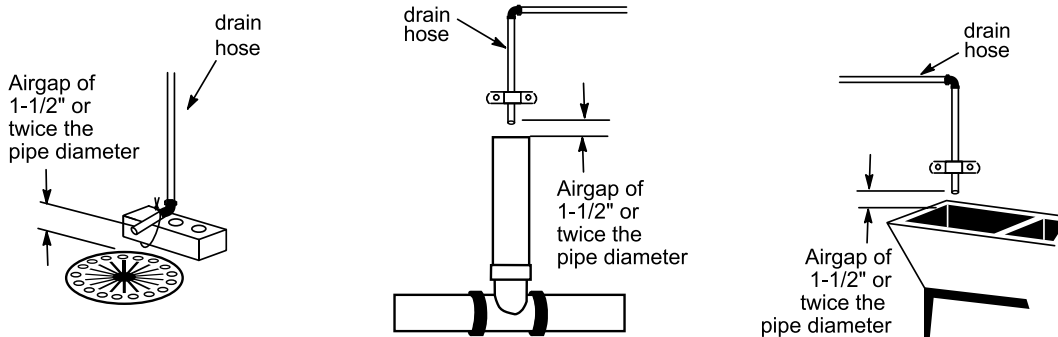

TYPICAL DRAIN LINE INSTALLATIONS

Programming Procedures

1. Set Time of Day

Typically, time of day should only need to be set after extended power outages or when daylight saving time begins or ends or after the battery has been replaced. If an extended power outage occurs, the time of day will flash on and off indicating that the time should be reset. To set the clock:

STEP 1 – Press the **CLOCK** button.

STEP 2 – Set the hour of the day using **+** or **-** buttons. AM/PM toggles after 12. Press **NEXT** to go to step 3.

STEP 3 – Set the minutes using **+** or **-** buttons. Press **NEXT** to go to step 4 or **REGEN** to return to previous step.

STEP 4 – Set the day of the week using **+** or **-** buttons. Press **NEXT** to exit clock setting or **REGEN** to return to previous step.

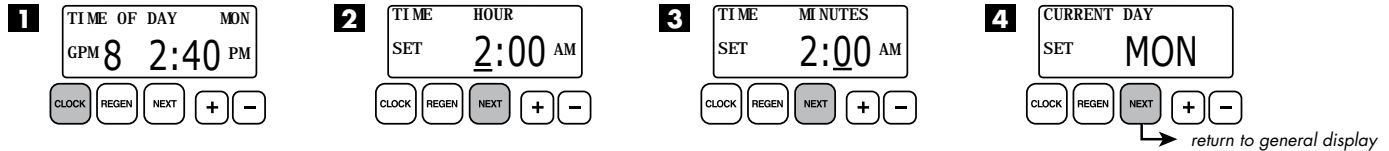

2. Programming

The manufacturer has preset the control valve to back flush once a day, with a 300 Gallon Setting between regenerations. If 300 gallons are used the unit will regenerate at the next regeneration time.

STEP 1 – Press and hold the **NEXT** and **+** buttons simultaneously for 3 seconds.

STEP 2 – **DAYS BETWEEN REGENERATION (DAY OVERRIDE):** The manufacturer has factory set OFF as the default. When set to “OFF”, regeneration initiation is based solely on gallons used. If any number is set (allowable range from 1 to 28), a regeneration initiation will be called for on that day even if a sufficient number of gallons were not used to call for a regeneration.

Set Day Override using **+** or **-** buttons:

- set number of days between regeneration (1 to 28); or
- set to “OFF”

STEP 3 – **IMMEDIATE REGENERATION:** The manufacturer has set the regeneration to occur when zero gallons remain. When this occurs, the standby tank will switch into service and provide treated water while the tank requiring regeneration will start this process.

STEP 4 – **SERVICE ALARM GALLONS:** The manufacturer has factory set “OFF” as the default. This feature is used to signal service into the future. This is typically set by the installing dealer to warn homeowner that service is required after a preset number of gallons have been consumed. If the feature is active, a specific gallon amount will appear.

STEP 5 – **SERVICE ALARM TIME:** The manufacturer has factory set “OFF” as the default. This feature is used to signal service into the future. This is typically set by the installing dealer to warn homeowner that service is required after a period of time has passed. If the feature is active, a specific number of days will appear.

STEP 6 – **ALARM BUZZER:** Use the **+** or **-** buttons to turn the alarm ON or OFF. Unit is set to OFF by default. Alarm will sound after a regeneration warning the owner of possible valve errors or other issues. This alarm is a short 0.5 second burst every 3 seconds. When alarm buzzer is set to ON, pressing the **NEXT** button proceeds to the Alarm Start Time screen. This feature allows the installer to choose a time when the owner will be home or awake to hear the alarm.

BUZZER START TIME: Press the **+** or **-** buttons to select the hour when the buzzer should begin sounding. AM/PM toggles after 12. Default setting is 6:00 a.m.

BUZZER STOP TIME: Press the **+** or **-** buttons to select the hour when the buzzer should stop sounding. AM/PM toggles after 12. Default setting is 10:00 p.m.

STEP 7 – **BACKLIGHT DISPLAY CONTROL:** Use the **+** or **-** buttons to turn the backlight setting ON or OFF. If unit is set to OFF, the backlight will turn off after 5 minutes of inactivity.

Press **NEXT** to return to General Display.

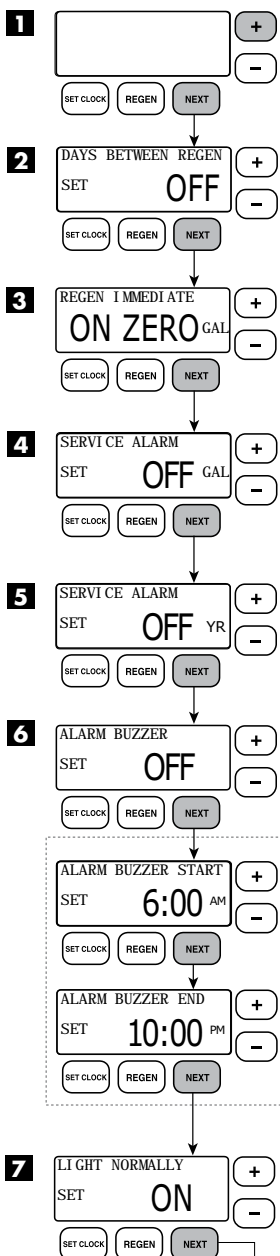

Return to general display. ←

Start-up Procedures

The system regeneration sequence for a Standard Installation configuration is in the following order. To change the cycle order, consult the unit's Dealer Manual or contact the manufacturer.

Standard Installation Regeneration Sequence:

1. Backwash (2 minutes)
2. Rinse (1 minute)

The system is now ready for filling with water and for testing.

1. With the UF Filter Control Valve in bypass mode and unplugged (**Fig. 2 on page 4**) turn water on slowly. Water will fill system (not the membrane tank) including the pre-filter and post storage tank if used. Run water preferably at a laundry sink or tub faucet and allow plumbing to clear. Check for any leaks at this time in newly installed plumbing.
2. With the UF Filter Control Valve in bypass mode (**Fig. 2 on page 4**) plug control valve transformer into a permanent 110 volt outlet. The valve should be in normal operating mode where the display shows either time of day or gallons remaining, press and hold the **REGEN** button until the motor starts. The display will indicate the unit is in the regeneration mode. Release the button.
3. The unit is now in backwash position, this will be indicated on the control valve screen. Do not turn the water on.
4. Push **REGEN** button to advance the control valve to the rinse position. Once the valve enters the rinse position, unplug from receptacle. Leaving the valve in this position, open the inlet bypass valve to the system slowly, this will allow water to enter the tank slowly and flush the air to the drain. Once system is full, a steady stream of water will be observed at the drain. Open inlet bypass valve completely (**Fig. 3 on page 4**) and allow water to drain for 20 minutes. This will allow for proper flushing of the membrane and any preservatives used in the manufacturing and storage process.
5. Plug unit back into the receptacle.
6. Push **REGEN** button and system will return to the normal service position.
7. Again, follow steps 2–6 with the bypass inlet valve open. This will allow for any additional air to be dispelled from the system. It is not necessary to flush for 20 minutes again as in step 4. When or if no air is observed at the drain, proceed to step 8.
8. Advance control valve to the service position. Upon returning to the service position, open the outlet valve of the bypass to the normal operating position. **NOTE:** Bypass valves should be in the normal operation position. (**Fig.1 on page 4**).
9. Open a faucet at a laundry sink or at a bath tub. Water will now be flowing through the UF filter system. Run system until water is clear.

NOTE: If a back flush tank is being used, this will need to be isolated during startup to ensure that no disinfection chemicals enter the tank. This could cause premature failure of the tank.

Operation & Maintenance

1. GENERAL OPERATION: When the system is operating, one of six displays may be shown and will alternate with the installing dealer's name and phone number for future service. Pressing **NEXT** will alternate between the displays.

1. **Time of Day Screen:** Displays the current time of day, the day of the week, and flow rate. Letter indicates which tank is in service.
2. **Flow Rate Screen:** Displays the current treated water flow rate through tank A or B in Gallons Per Minute.
3. **Vacation Mode Screen:** Allows the system to be "shut down" when there will be no water usage for an extended period of time.
4. **Capacity Remaining Screen:** Displays the amount of gallons of treated water remaining for the tank in service until the system triggers a regeneration and switches to the other tank.
5. **Days to a Regen Screen:** Displays the number of days until the system triggers a regeneration. Based on the days override value.
6. **Dealer Name Screen:** Displays dealer specific name and phone number. This scrolling display will only appear if set by the dealer.

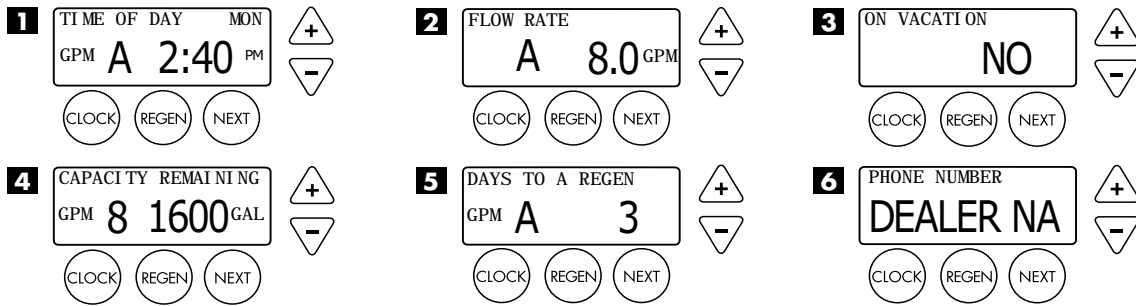

2. VACATION MODE: This feature may be used to "shut down" the system for a period of time by preventing the unit from regenerating. The manufacturer has factory set "OFF" as the default. Turn feature "OFF" or "ON" using the **+** or **-** buttons. When turned "ON", the unit will remain in Vacation Mode until it is exited. There are two ways that a unit can exit Vacation Mode:

Manually: The user may manually exit Vacation Mode by changing the setting from "ON" to "OFF". Once switched off, a delayed regeneration will queue for that night. Vacation mode may also be manually exited by holding the REGEN button to force an immediate regeneration.

Automatically: The unit will automatically exit Vacation Mode once water usage has resumed. After fifty gallons of water is used, the unit will set to resume normal operation and a delayed regeneration will queue for that night.

NOTE: In some instances, if a regeneration has been queued and the unit is taken out of Vacation Mode (manually or automatically), the unit will trigger an immediate regeneration instead of a delayed regeneration. For example, if the unit's maximum Days Between Regeneration is reached while the unit is in Vacation Mode, an immediate regeneration will trigger as soon as the unit is taken out of Vacation Mode.



CAUTION: Depending on the severity of water conditions and the length of no water usage, it may not be recommended to use this feature. Please contact dealer or manufacturer for more information.

3. REGENERATION MODE: Standard UF Filters typically regenerate once per day. Regenerations occur once the capacity of the tank providing treated water reaches zero gallons. At this time, the online tank will transfer and put the standby tank online so that there is no disruption of treated water service. This is a short (2 minute) back flush of the membrane. When the system begins to regenerate, the display will include information about the step of the regeneration process and the time remaining for that step to be completed. The system runs through the steps automatically and will reset itself to provide treated water when the regeneration has been completed.

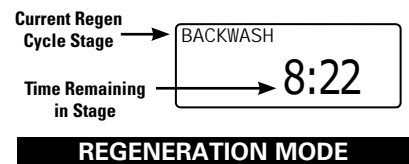

4. MANUAL REGENERATION: Sometimes there is a need to regenerate before the control valve calls for it. This may be needed if a period of heavy water use is anticipated or if a pressure drop is noticed in the system.

- To initiate a manual regeneration at the next preset regeneration time, press and release **REGEN**. The words "REGEN TODAY" will flash on the display to indicate that the system will regenerate at the next regeneration time (set in Programming). If you pressed the **REGEN** button in error, pressing the button again will cancel the command.
- To initiate a manual regeneration immediately, press and hold the **REGEN** button for three seconds. The system will begin to regenerate immediately. **This command cannot be cancelled.**

REGEN TODAY and TIME OF DAY will flash alternately if a regeneration is expected tonight.

REGEN TODAY MON
GPM 8 2:40 PM

MANUAL REGEN

On Standard UF Filters once a manual regeneration is initiated, the unit will proceed to the backwash position. In this position a two minute flush to the drain will occur. This backwash allows for flushing of particulates from the membrane to the drain. Once this is complete, the unit transfers to a one minute rinse. This rinses the tank of these same particles.

5. POWER LOSS AND BATTERY REPLACEMENT: If an extended power outage occurs, the control valve will retain the time of day settings until the board's battery is depleted. Once the battery is depleted, the display will appear dark and absent of any information. If this occurs, following these steps will determine if the problem is a low battery or a board failure.

To determine if the battery is depleted:

1. Remove valve cover. Disconnect power from PC Board at the four pin connector at the bottom of the board.
2. Wait five minutes for board to de-energize. Remove battery with a non-conductive/non-metallic material. Reference the Parts Breakdown section of this manual for location.
3. Wait five minutes for board to de-energize.
4. With the battery out, re-connect the power supply to the board. The board's display should begin to show information.

This indicates that the board is operating correctly. If the display does not work, call installing dealer for service.

5. To replace with new battery, unplug transformer from outlet. Install a 3 volt Lithium Coin Cell type 2032 battery, available at most stores. Plug unit back into outlet.

It is important to replace the battery with the valve unplugged to avoid causing a short and potentially ruining the board.

6. Reset the time of day (see programming procedures) and initiate regeneration (see operating displays and maintenance).

If these procedures do not remedy the problem, please consult the installing dealer for service.

6. ERROR MESSAGE: If the word "ERROR" appears and flashes alternately with the dealer name and phone number, record the ERROR number and contact your servicing dealer promptly. This indicates that the control valve was not able to function properly.

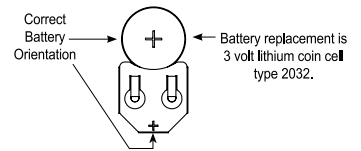

When replacing the battery, align positives and push down to fully seat.



BATTERY REPLACEMENT



ERROR SCREEN

7. AUDIBLE ALARM: This control valve is equipped with an audible alarm and visual alarm. This alarm is set by the installing dealer and is used to warn the owner of possible valve errors or other issues.

To turn off alarm: If the audible alarm sounds, press any button on the face of the control valve to turn off and call the dealer for service.

Troubleshooting Guide

PROBLEM	CAUSE	CORRECTION
1. No display on PC board.	A. Depleted battery.	A. See Operating Display and Maintenance section.
	B. Control valve power adapter not plugged into outlet or power cord end not connected to PC board connection.	B. Plug power adapter into outlet or connect power cord end to PC board connection.
	C. Improper power supply.	C. Verify proper voltage is being delivered to PC board.
	D. Defective power adapter.	D. Replace power adapter.
	E. Defective PC board.	E. Replace PC board.
	F. No power at electric outlet.	F. Repair outlet or use working outlet.
2. PC board does not display correct time of day.	A. Power adapter plugged into electric outlet controlled by light switch.	A. Use uninterrupted outlet.
	B. Tripped breaker switch and/or tripped GFI.	B. Reset breaker switch and/or GFI switch.
	C. Power outage.	C. Reset time of day. If PC board has battery back up present the battery may be depleted. See front cover and drive assembly drawing for instructions.
	D. Defective PC board.	D. Replace PC board.
3. Display does not indicate that water is flowing. Refer to user instructions for how the display indicates water is flowing.	A. Bypass valve in bypass position.	A. Turn bypass handles to place bypass in service position.
	B. Meter is not connected to meter connection on PC board.	B. Connect meter to three pin connection labeled METER on PC board.
	C. Restricted/stalled meter turbine.	C. Remove meter and check for rotation or foreign material.
	D. Meter wire not installed securely into three pin connector.	D. Verify meter cable wires are installed securely into three pin connector labeled METER.
	E. Defective meter.	E. Replace meter.
	F. Defective PC board.	F. Replace PC board.
4. Control valve regenerates at wrong time of day.	A. Power outage.	A. Reset time of day. If PC board has battery back up present the battery may be depleted. See front cover and drive assembly drawing for instructions.
	B. Time of day not set correctly.	B. Reset to correct time of day.
	C. Time of regeneration set incorrectly.	C. Reset regeneration time.
	D. Control valve set at immediate regeneration.	D. Check programming setting and reset to DELAYED (for a delayed regen time).
5. Time of day flashes on and off.	A. Power outage.	A. Reset time of day. If PC board has battery back up present the battery may be depleted. See front cover and drive assembly drawing for instructions.
6. Control valve does not regenerate automatically when the correct button(s) is pressed and held. For timeclock valves the buttons are + or -. For all other valves the button is REGEN.	A. Broken drive gear or drive cap assembly.	A. Replace drive gear or drive cap assembly.
	B. Broken piston rod.	B. Replace piston rod.
	C. Defective PC board.	C. Defective PC board.
	D. Cover installed incorrectly.	D. Reinstall cover.

Troubleshooting Guide

PROBLEM	CAUSE	CORRECTION
7. Control valve does not regenerate automatically but does when the correct button(s) is depressed and held. For timeclock valves the buttons are + or -. For all other valves the button is REGEN.	A. Bypass valve in bypass position.	A. Turn bypass handles to place bypass in service position.
	B. Meter is not connected to meter connection on PC board.	B. Connect meter to three pin connection labeled METER on PC board.
	C. Restricted/stalled meter turbine.	C. Remove meter and check for rotation or foreign material.
	D. Incorrect programming.	D. Check for programming error.
	E. Meter wire not installed securely into three pin connector.	E. Verify meter cable wires are installed securely into three pin connector labeled METER.
	F. Defective meter.	F. Replace meter.
	G. Defective PC board.	G. Replace PC board.
8. Hard or untreated water is being delivered.	A. Bypass valve is open or faulty.	A. Fully close bypass valve or replace.
	B. Media is exhausted due to high water usage.	B. Check program settings or diagnostics for abnormal water usage.
	C. Meter not registering.	C. Remove meter and check for rotation or foreign material.
	D. Water quality fluctuation.	D. Test water and adjust program values accordingly.
	E. No regenerant or low level of regenerant in regenerant tank.	E. Add proper regenerant to tank.
	F. Control fails to draw in regenerant.	F. Refer to Troubleshooting Guide number 12.
	G. Insufficient regenerant level in regenerant tank.	G. Check refill setting in programming. Check refill flow control for restrictions or debris and, if necessary, replace.
	H. Damaged seal/stack assembly/piston.	H. Replace seal/stack assembly and/or piston.
	I. Control valve body type and piston type mix matched.	I. Verify proper control valve body type and piston type match.
	J. Fouled media bed.	J. Replace media bed.
9. Control valve uses too much regenerant.	A. Improper refill setting.	A. Check refill setting.
	B. Improper program settings.	B. Check program setting to make sure they are specific to the water quality and application needs.
	C. Control valve regenerates frequently.	C. Check for leaking fixtures that may be exhausting capacity or system is undersized.
10. Residual regenerant being delivered to service.	A. Low water pressure.	A. Check incoming water pressure – water pressure must remain at minimum of 25 psi.
	B. Incorrect, damaged, or restricted injector.	B. Replace injector with correct size for the application.
	C. Restricted drain line.	C. Check drain line for restrictions or debris and remove any obstructions.
11. Excessive water in regenerant tank.	A. Improper program settings.	A. Check refill setting.
	B. Plugged injector.	B. Remove injector and replace.
	C. Drive cap assembly not tightened in properly.	C. Re-tighten the drive cap assembly.
	D. Damaged seal/stack assembly/piston.	D. Replace seal/stack assembly and/or piston.
	E. Restricted or kinked drain line.	E. Check drain line for restrictions or debris and or unkink drain line.
	F. Plugged backwash flow controller.	F. Remove backwash flow controller and replace, if necessary.
	G. Missing refill flow controller.	G. Install refill flow controller.
	H. Brine tube not inserted properly into brine elbow in brine tank.	H. Install tube all the way into elbow.

Troubleshooting Guide

PROBLEM	CAUSE	CORRECTION
12. Control valve fails to draw in regenerant.	A. Injector is plugged.	A. Remove injector and replace.
	B. Faulty regenerant piston.	B. Replace regenerant piston.
	C. Regenerant line connection leak.	C. Inspect regenerant line for air leak.
	D. Drain line restriction or debris cause excess back pressure.	D. Inspect drain line and remove to correct restriction.
	E. Drain line too long or too high.	E. Shorten length and or height.
	F. Low water pressure.	F. Check incoming water pressure – water pressure must remain at minimum of 25 psi.
13. Water running to drain.	A. Power outage during regeneration.	A. Upon power being restored control will finish the remaining regeneration time. Reset time of day. If PC board has battery back up present the battery may be depleted. See front cover and drive assembly drawing for instructions.
	B. Damaged seal/stack assembly.	B. Replace seal/stack assembly.
	C. Piston assembly failure.	C. Replace piston assembly.
	D. Drive cap assembly not tightened in properly.	D. Re-tighten the drive cap assembly.
14. E1, Err – 1001, Err – 101 = Control unable to sense motor movement.	A. Motor not inserted full to engage pinion, motor wires broken or disconnected.	A. Disconnect power, make sure motor is fully engaged, check for broken wires, make sure two pin connector on motor is connected to the two pin connection on the PC board labeled MOTOR. Press NEXT and REGEN buttons for 3 seconds to resynchronize software with piston position or disconnect power supply from PC board for 5 seconds and then reconnect.
	B. PC board not properly snapped into drive bracket.	B. Properly snap PC board into drive bracket and then Press NEXT and REGEN buttons for 3 seconds to resynchronize software with piston position or disconnect power supply from PC board for 5 seconds and then reconnect.
	C. Missing drive gears.	C. Replace missing gears.
	D. Motor does not drive/run.	D. Replace motor.
	E. Viewing eye or encoder is blocked or damaged.	E. clear viewing eye on board, on drive bracket, or replace PC board if no debris is found.
15. E2, Err – 1002, Err – 102 = Excessive Motor Draw.	A. Foreign material is lodged in control valve.	A. Open up control valve and pull out piston assembly and seal/stack assembly for inspection. Press NEXT and REGEN buttons for 3 seconds to resynchronize software with piston position or disconnect power supply from PC board for 5 seconds and then reconnect.
	B. Mechanical binding.	B. Check piston and seal/stack assembly, check reduction gears, check drive bracket and main drive gear interface. Press NEXT and REGEN buttons for 3 seconds to resynchronize software with piston position or disconnect power supply from PC board for 5 seconds and then reconnect.
	C. Drive cap too loose.	C. Completely tighten drive cap assembly.
	D. Drive cap not “clicked” into backplate.	D. Verify that backplate is properly “clicked” into place.

Troubleshooting Guide

PROBLEM	CAUSE	CORRECTION
16. E3, Err – 1003, Err – 103 = Control valve motor ran too long and was unable to find the next cycle position.	A. Drive bracket not snapped in properly and out enough that reduction gears and drive gear do not interface.	A. Snap drive bracket in properly then Press NEXT and REGEN buttons for 3 seconds to resynchronize software with piston position or disconnect power supply from PC board for 5 seconds and then reconnect.
17. E4, Err – 1004, Err – 104 = Control valve motor ran too long and timed out trying to reach home position.	A. Drive bracket not snapped in properly and out enough that reduction gears and drive gear do not interface.	A. Snap drive bracket in properly then Press NEXT and REGEN buttons for 3 seconds to resynchronize software with piston position or disconnect power supply from PC board for 5 seconds and then reconnect.
	B. Piston not connected to drive cap.	B. Connect or replace (if damaged) piston/drive cap.
18. Err – 1006, Err – 106, Err – 116 = MAV/ SEPS/ NHBP/ AUX MAV valve motor ran too long and unable to find the proper park position. ●Motorized Alternating Valve = MAV ●Separate Source = SEPS ●No Hard Water Bypass = NHBP ●Auxiliary MAV = AUX MAV	A. Control valve programmed for ALT A or B, nHbP, SEPS, or AUX MAV with out having a MAV or NHBP valve attached to operate that function.	A. Press NEXT and REGEN buttons for 3 seconds to resynchronize software with piston position or disconnect power supply from PC board for 5 seconds and then reconnect. Then reprogram valve to proper setting.
	B. MAV/NHBP motor wire not connected to PC board.	B. Connect MAV/NHBP motor to PC board two pin connection labeled DRIVE. Press NEXT and REGEN buttons for 3 seconds to resynchronize software with piston position or disconnect power supply from PC board for 5 seconds and then reconnect.
	C. MAV/NHBP motor not fully engaged with reduction gears.	C. Properly insert motor into casing, do not force into casing Press NEXT and REGEN buttons for 3 seconds to resynchronize software with piston position or disconnect power supply from PC board for 5 seconds and then reconnect.
	D. Foreign matter built up on piston and stack assemblies creating friction and drag enough to time out motor.	D. Replace piston and stack assemblies. Press NEXT and REGEN buttons for 3 seconds to resynchronize software with piston position or disconnect power supply from PC board for 5 seconds and then reconnect.
19. Err – 1007, Err – 107, Err – 117 = MAV/ SEPS/NHBP/ AUX MAV valve motor ran too short (stalled) while looking for proper park position. ●Motorized Alternating Valve = MAV ●Separate Source = SEPS ●No Hard Water Bypass = NHBP ●Auxiliary MAV = AUX MAV	A. Foreign material is lodged in MAV/NHBP valve.	A. Open up MAV/NHBP valve and check piston and seal/ stack assembly for foreign material. Press NEXT and REGEN buttons for 3 seconds to resynchronize software with piston position or disconnect power supply from PC board for 5 seconds and then reconnect.
	B. Mechanical binding.	B. Check piston and seal/stack assembly, check reduction gears, drive gear interface, and check MAV/NHBP black drive pinion on motor for being jammed into motor body. Press NEXT and REGEN buttons for 3 seconds to resynchronize software with piston position or disconnect power supply from PC board for 5 seconds and then reconnect.

Troubleshooting Guide

PROBLEM	CAUSE	CORRECTION
20. Err – 201 200 errors are only viewable in history screens. These do not flash when error occurs.	A. Invalid regeneration cycle step detected.	A. Replace PC board.
21. Err – 202 200 errors are only viewable in history screens. These do not flash when error occurs.	A. Short power disruption.	A. Check transformer voltage and verify power source.
	B. Foreign material dislodged.	B. Check piston and stack for damage.
22. Err – 204 = Leak detected 200 errors are only viewable in history screens. These do not flash when error occurs.	A. Occurs when dP input is active for “ALARM” and the input is closed. The alarm buzzer will activate and the screen will display the error.	A. Check for low flow leak. Press NEXT and REGEN buttons for 3 seconds to resynchronize software with piston position or disconnect power supply from PC Board for 5 seconds and then reconnect to clear error.
23. Err – 400* Memory Errors *All 400 errors pertain to memory related errors. 400 and 200 errors are only viewable in history screens. These do not flash when error occurs.	A. Depleted Battery.	A. See Operating Display and Maintenance section.
	B. Defective PC Board.	B. Replace PC board.

Replacement Parts

FRONT COVER AND DRIVE ASSEMBLY

Item #	Part #	Description	Qty.
1	CV3540-NOLAB	Black cover	1
2	CV3107-01	Motor Assembly	1
3	CV32002-A	Drive assembly (includes #5 and #6)	1
4	CV4022WU	PC board (standard)	1
5	CV3110	Drive gear, 12 x 36	3
6	CV3109	Drive gear cover	1
not shown	CV3186	Transformer, 110V-12V, AC (standard)	1
	CV3543	Optional weather cover	1

NOTE: Battery Location

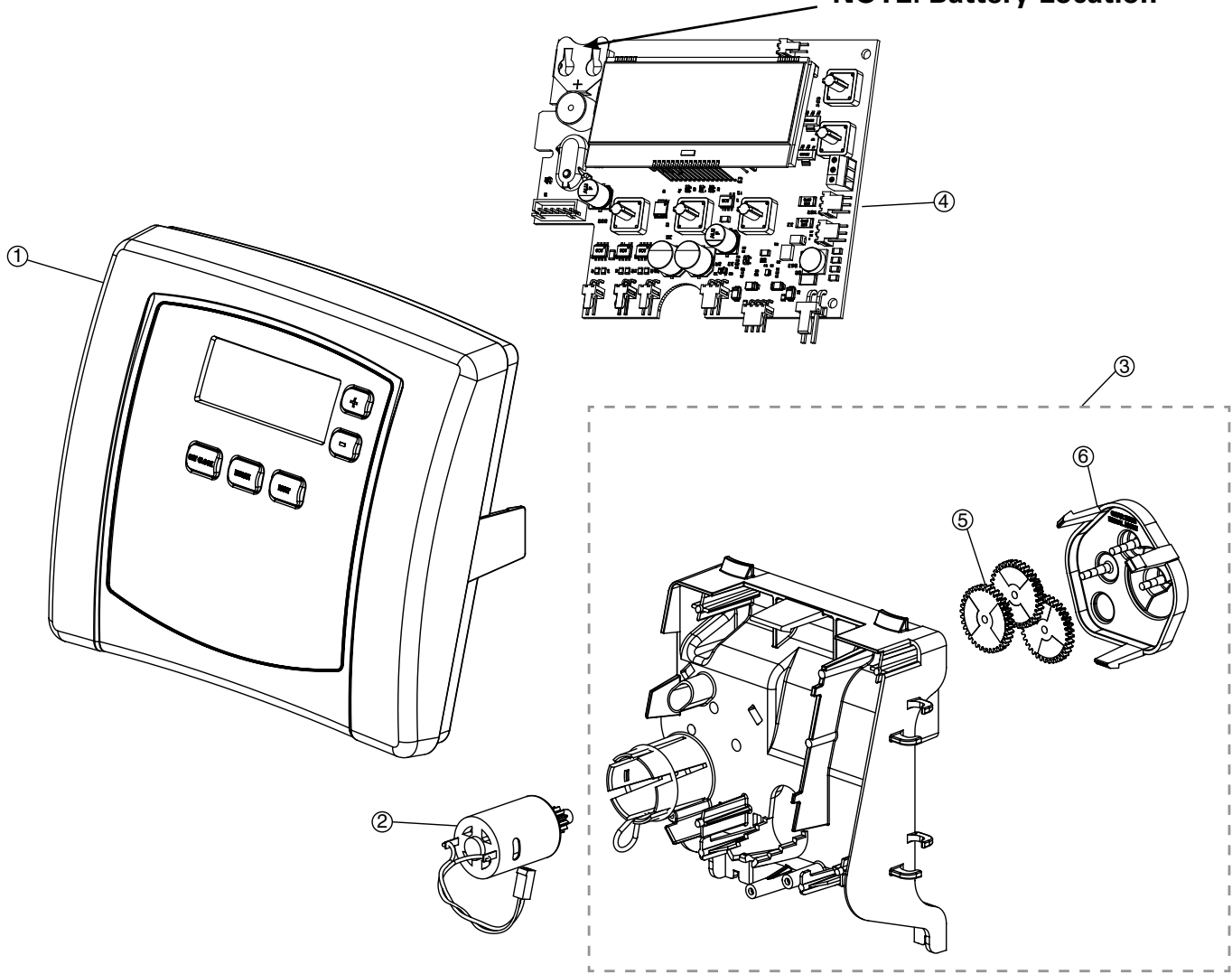

Replacement Parts

PISTON ASSEMBLY

Item #	Legacy Part #	Current Part #	Description	Qty.
1	CV3005-02	100249844	1" spacer stack assembly	1
	CV3430-01	100249865	1.25" spacer stack assembly	1
2	CV3004	100246196	Drive cap assembly	1
3	CV3135	100246281	O-ring 228 (drive cap o-ring)	1
4	CV3011	100246232	1" piston assembly downflow	1
	CV3011-01	100246233	1" piston assembly upflow	1
5	CV3174	100246296	Regenerant piston	1
6	CV3541	100249867	Drive backplate	1

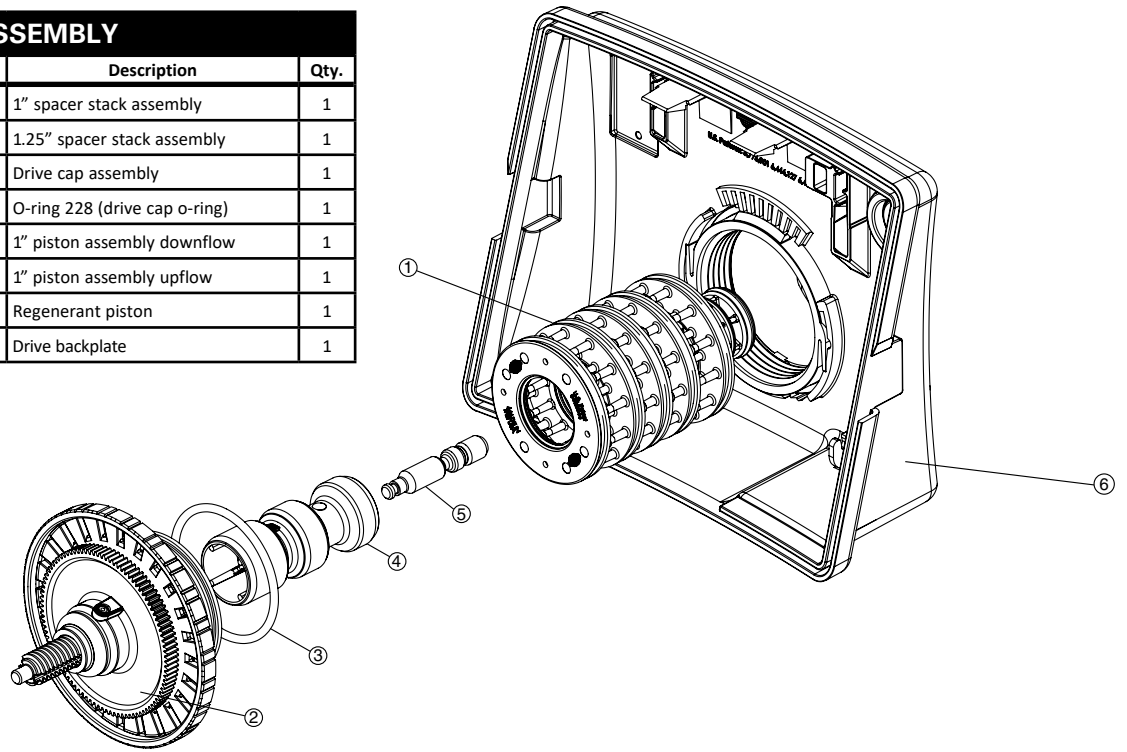

TANK O-RINGS

Item #	Legacy Part #	Current Part #	Description	Qty.
1	CV3180	100246307	Base O-Ring	1
2	CV3105	100246272	O-Ring 215	1
	CV3358	100246341	O-Ring 219 (for 1.25" distributor tubes)	1

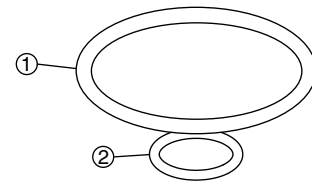

IN/OUT HEAD (FOR TANK B)

Item #	Legacy Part #	Current Part #	Description	Qty.
	CD1400	100245769	1191 In/Out head (includes O-rings)	1
1	CV3180	100246307	O-ring 337	1
2	CV3105	100246272	O-ring 215	1

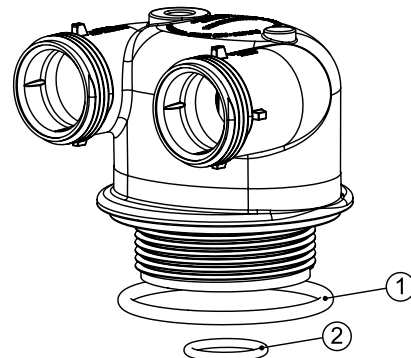

Replacement Parts

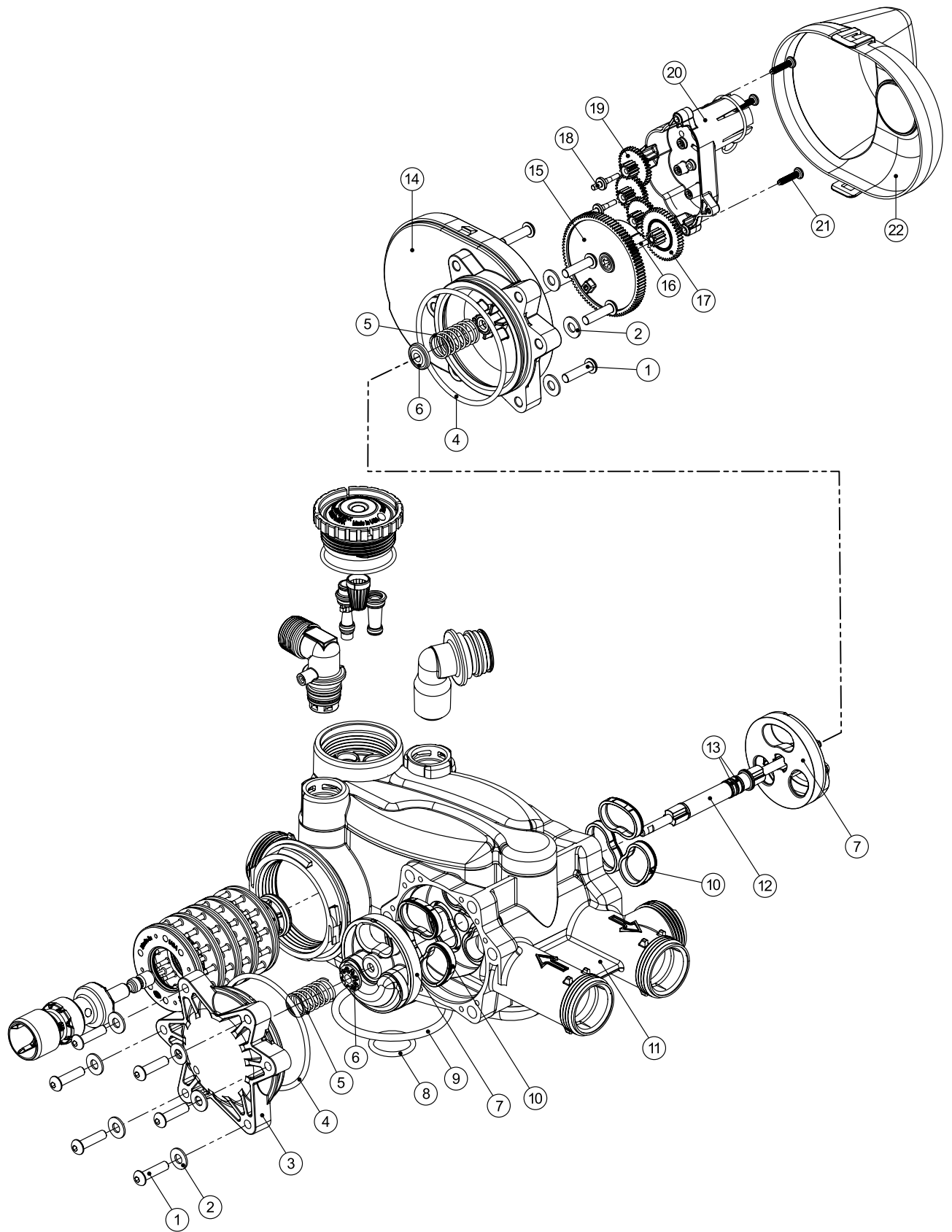

Replacement Parts

TWIN TRANSFER			
Item No.	Part No.	Description	Qty.
1	CV3470	Screw, BHC 1/4 - 20 x 1 SS	12
2	CV3724	Washer, flat SS 1/4	12
3	CV4005-01	T1 transfer cap assembly	1
4	CV4029	O-ring 236	2
5	CV4015	T1 transfer spring	2
6	CV4014	T1 transfer spring support	2
7	CV4036	T1 rotor disk assembly	2
8	CV3105	O-ring 215 (distributor tube)	1
9	CV3180	O-ring 337	1
10	CV4016	T1 transfer seal	6
11	CV3031	T1 body sft wtr regen	1
12	CV4023	T1 transfer drive shaft assembly	1
13	CV3287	O-ring 110	2
14	CV4006-01	T1 transfer drive cap assembly	1
15	CV4011-01	T1 transfer drive gear assembly	1
16	CV4012	T1 transfer drive gear axle	1
17	CV4013	T1 transfer reduction gear	1
18	CV3264	WS2H bypass reduction gear axle	3
19	CV3110	WS1 drive reducing gear 12 x 36	3
20	CV3262-01	WS1.5 & 2 ALT/2BY reduction gear cover assembly	1
21	CV3592	Screw, #8-1 PHPN T-25 SS	3
22	CV4049	T1 cover assembly	1
not shown	CV4043	T1 transfer motor assembly	1
not shown	CV3151	WS1 nut 1 QC	1
not shown	CV4055*	Twin tank meter assembly	1
not shown	CV4017-01	T1 interconnect fitting assembly	1
not shown	D1400	1191 In/Out head	1
not shown	CD1225-05	Top basket softener (optional)	1
*This water meter should not be used as the primary monitoring device for critical or health effect applications.			

Replacement Parts

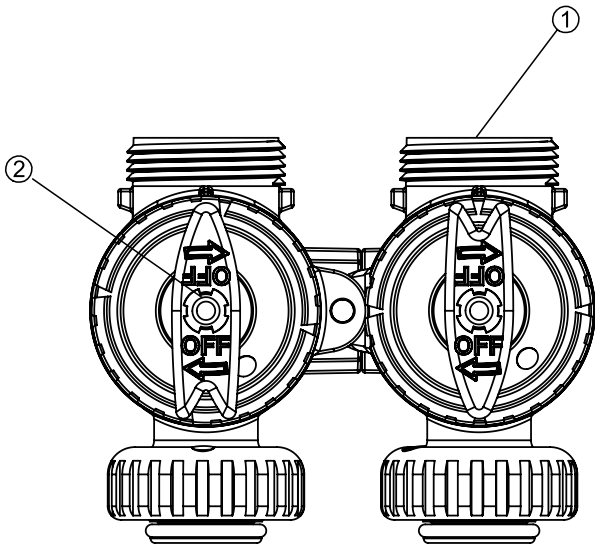

BYPASS VALVE			
Item No.	Part No.	Description	Qty.
1	CV3006	Bypass assembly	1
2	CV3147	Bypass handles	2

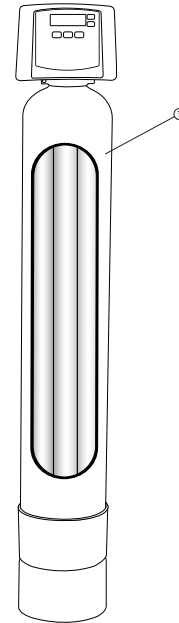

UF REPLACEMENT TANK			
Item No.	Part No.	Description	Qty.
1	680842XBBK00UF0	Poly-UF Replacement Tank	1

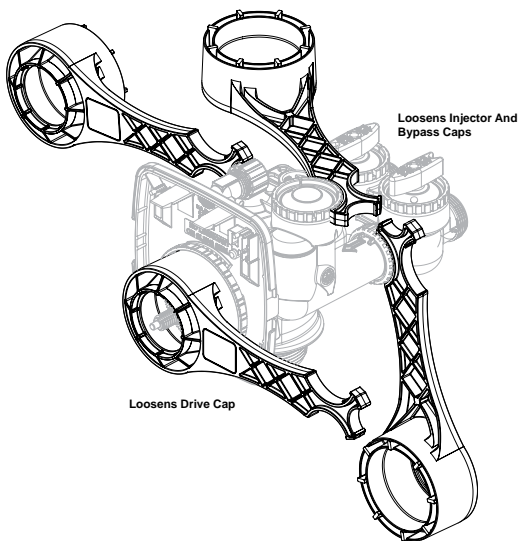

SERVICE WRENCH - CV3193-02

Although no tools are necessary to assemble or disassemble the valve, the Service Wrench, (shown in various positions on the valve) is available to aid in assembly or disassembly.

Replacement Parts

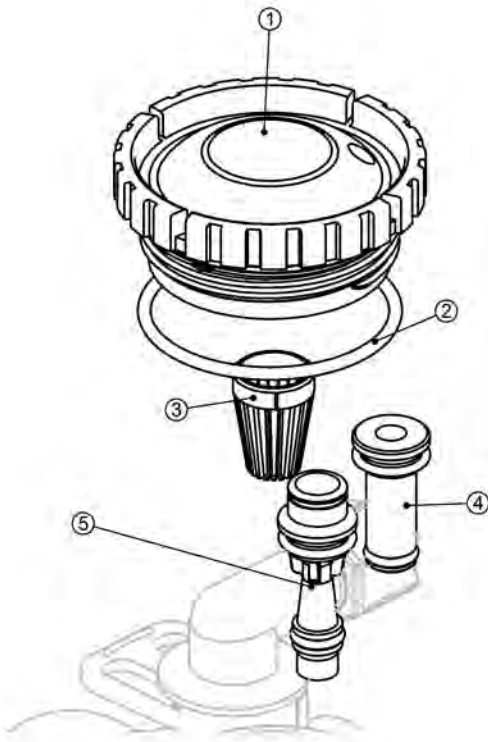

INJECTOR ASSEMBLIES			
Item No.	Part No.	Description	Qty.
1	CV3176	Injector cap	1
2	CV3152	O-ring 135	1
3	CV3177-01	Injector screen	1
4	CV3010-1Z	Injector assembly plug	1
5	CV3010-1A	A injector assembly, black	1
	CV3010-1B	B injector assembly, brown	
	CV3010-1C	C injector assembly, violet	
	CV3010-1D	D injector assembly, red	
	CV3010-1E	E injector assembly, white	
	CV3010-1F	F injector assembly, blue	
	CV3010-1G	G injector assembly, yellow	
	CV3010-1H	H injector assembly, green	
	CV3010-1I	I injector assembly, orange	
	CV3010-1J	J injector assembly, light blue	
CV3010-1K	K injector assembly, light green		
not shown	CV3170	O-ring 011, lower	*
not shown	CV3171	O-ring 013, upper	*

***The injector plug and the injector each use one lower and one upper o-ring**

WATER METER AND METER PLUG			
Item No.	Part No.	Description	Qty.
1	CV3151	Nut, 1" QC	1
2	CV4055	Twin Tank Meter assembly	1
3	CV3105	O-ring 215	1
4	CV3003-01	Meter plug assembly	1

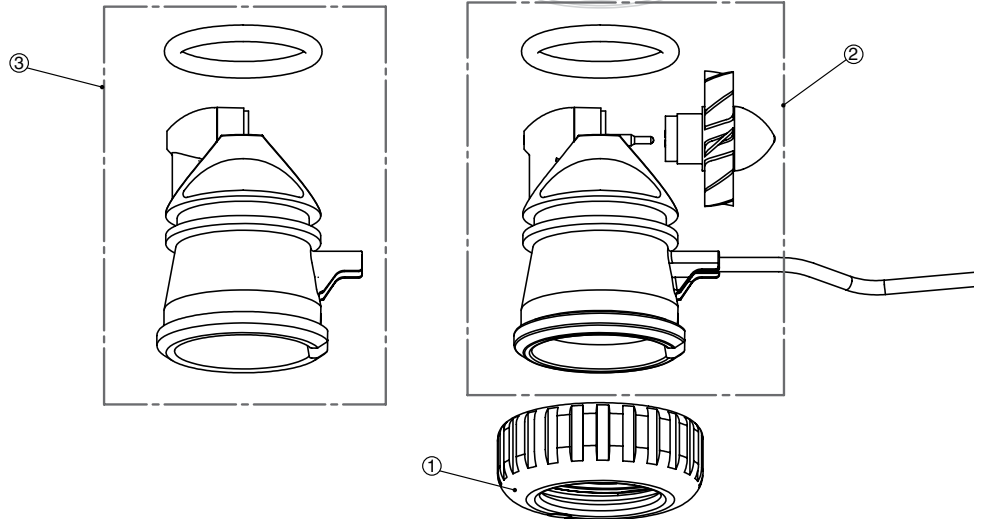

Replacement Parts

DRAIN LINE ASSEMBLY 3/4"			
Item No.	Part No.	Description	Qty.
1	CH4615	Elbow locking clip	1
2	CPKP10TS8-BULK	Optional insert, 5/8" tube	1
3	CV3192	Optional nut, 3/4" drain elbow	1
4	CV3158-02	Drain elbow, 3/4" NPT with O-ring	1
5	CV3163	O-ring 019	1
6	CV3159-01	DLFC retainer assembly	1
7	CV3162-007	0.7 DLFC for 3/4" elbow	1
	CV3162-010	1.0 DLFC for 3/4" elbow	
	CV3162-013	1.3 DLFC for 3/4" elbow	
	CV3162-017	1.7 DLFC for 3/4" elbow	
	CV3162-022	2.2 DLFC for 3/4" elbow	
	CV3162-027	2.7 DLFC for 3/4" elbow	
	CV3162-032	3.2 DLFC for 3/4" elbow	
	CV3162-042	4.2 DLFC for 3/4" elbow	
	CV3162-053	5.3 DLFC for 3/4" elbow	
	CV3162-065	6.5 DLFC for 3/4" elbow	
CV3162-075	7.5 DLFC for 3/4" elbow		
8	CV3331	Drain elbow and retainer assembly	

Items 2 and 3, nut and insert are only used with 1/2" I.D. by 5/8" O.D. polytubing. For other piping material, the 3/4" NPT is used.

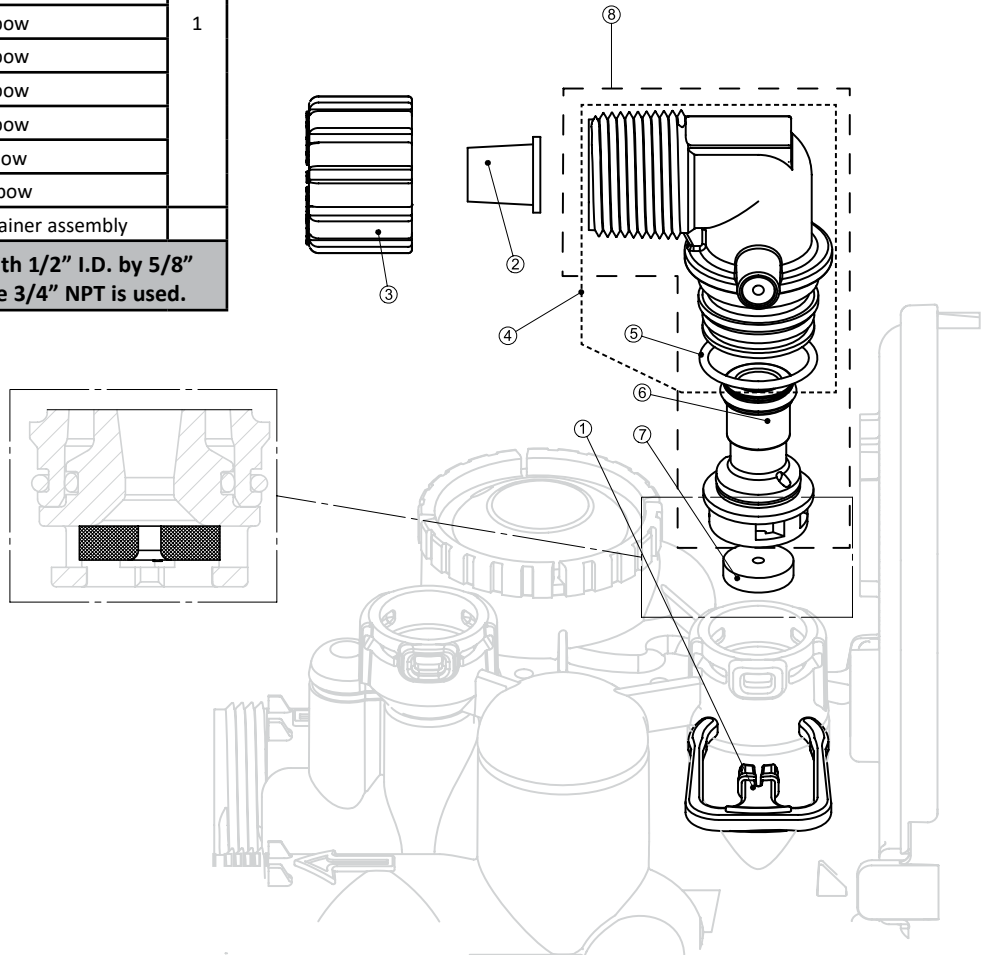

This page intentionally left blank.

Installation Fitting Assemblies

Fitting Installation Instructions

- Installation fittings are designed to accommodate minor plumbing misalignments, but are not designed to support the weight of a system or the plumbing.
- Slide nut on first, then the split ring and O-ring.
- Hand tighten the nut only.

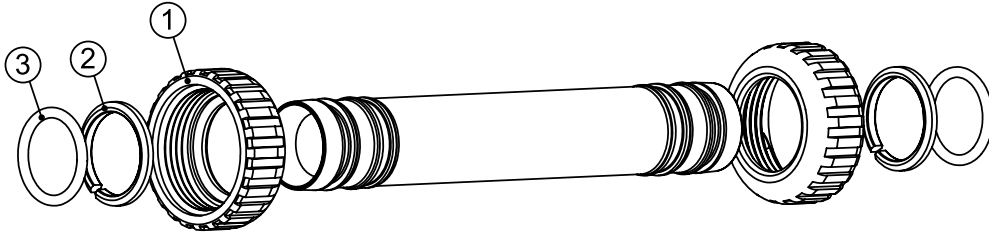

INTERCONNECT FITTING ASSEMBLY (UP TO 10" TANKS)				
Item #	Legacy Part #	Current Part #	Description	Qty.
	CV4017-01	100246436	Interconnect kit for tanks up to 10"	1
1	CV3151	100246287	Nut, 1" QC	4
2	CV3150	100246286	Split ring	4
3	CV3105	100246272	O-ring 215	4

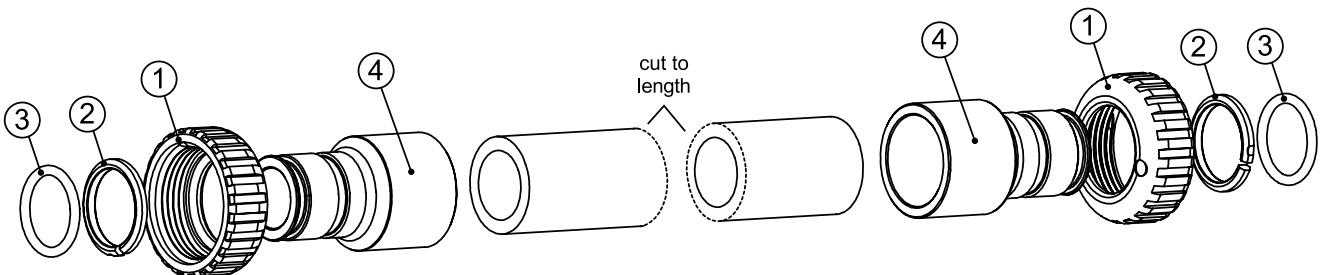

INTERCONNECT FITTING ASSEMBLY (12" & LARGER TANKS)				
Item #	Legacy Part #	Current Part #	Description	Qty.
	CV4052-01	100246445	Interconnect kit for tanks 12" and larger	1
1	CV3151	100246287	Nut, 1" QC	4
2	CV3150	100246286	Split ring	4
3	CV3105	100246272	O-ring 215	4
4	CV3352	100244126	1-1/4" & 1-1/2" PVC solvent fitting	4

Installation Fitting Assemblies

NOTE: Not all available fittings are displayed below. Contact manufacturer for optional fittings.

For All Assemblies

Item #	Legacy Part #	Current Part #	Description	Qty.
1	CV3151	100246287	Nut, 1" quick connect	2
2	CV3150	100246286	Split ring	2
3	CV3105	100246272	O-ring 215	2

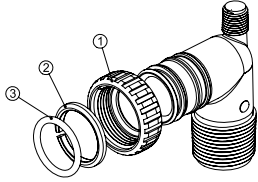

Legacy Part #	Current Part #	Description	Qty.
CV3007	100246197	1" PVC male NPT elbow assembly	2

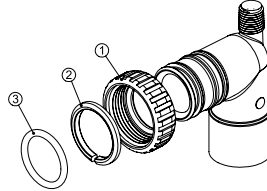

Legacy Part #	Current Part #	Description	Qty.
CV3007-01	100246198	3/4" & 1" PVC solvent elbow assembly	2

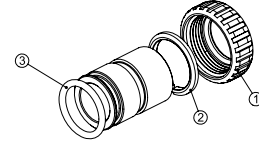

Legacy Part #	Current Part #	Description	Qty.
CV3007-02	100246199	1" brass sweat assembly	2

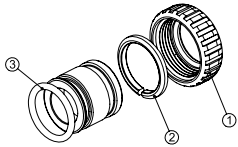

Legacy Part #	Current Part #	Description	Qty.
CV3007-03	100249846	3/4" brass sweat assembly	2

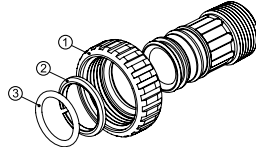

Legacy Part #	Current Part #	Description	Qty.
CV3007-04	100244506	1" plastic male NPT assembly	2

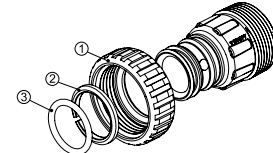

Legacy Part #	Current Part #	Description	Qty.
CV3007-05	100243921	1-1/4" plastic male assembly	2

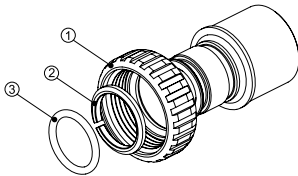

Legacy Part #	Current Part #	Description	Qty.
CV3007-09	100243922	1-1/4" & 1-1/2" brass sweat assembly	2

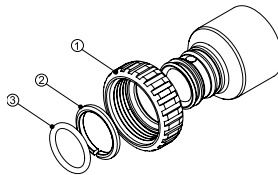

Legacy Part #	Current Part #	Description	Qty.
CV3007-07	100243375	1-1/4" & 1-1/2" PVC solvent assembly	2

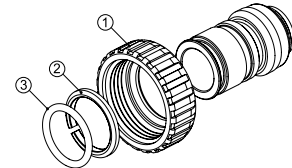

Legacy Part #	Current Part #	Description	Qty.
CV3007-12	100249847	3/4" brass shark bite assembly	2

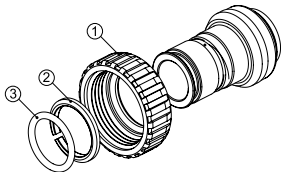

Legacy Part #	Current Part #	Description	Qty.
CV3007-13	100249848	1" brass shark bite assembly	2

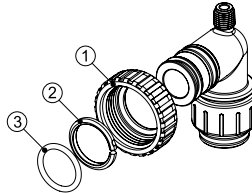

Legacy Part #	Current Part #	Description	Qty.
CV3007-15	100246200	3/4" john guest elbow assembly	2

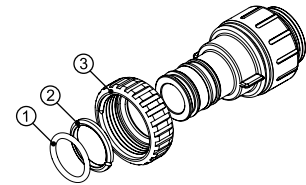

Legacy Part #	Current Part #	Description	Qty.
CV3007-17	100245045	1" john guest assembly	2

Specifications

Operating Specifications

Filtration Level (micron)	0.02
¹ Peak Flow Rate (at 77° F and 60 psi)	12 gpm
Continuous Flow Rate	10 gpm
Water Pressure Range (psi)	10-100
Water Temperature	35-100° F
Electrical Requirements (V/Hz)	100V/60Hz
Pipe Size	1"
Total Dimensions (inches):	
Media Tank and Valve	9"L x 27"W x 52"H

¹Flow rates depend upon pressure, temperature, and suspended solids being removed.

Application Specifications

Pre-filtration (micron)	5
Chlorine (ppm, continuous flow)	1
Iron, ppm	<0.3
Manganese, ppm	0.05
pH	3-11
Tannin	Variable*

*Molecular weights of tannins vary greatly. It is important that the filtration level be demonstrated prior to installation.

NOTE: This product is not certified as a microbiological purifier and should not be applied as a stand-alone disinfection solution for microbiologically unsafe water.



A. O. Smith Commercial Limited Warranty

WHO IS COVERED

This limited warranty is provided by A. O. Smith and applies only to the original owner who purchased and installed the A. O. Smith product for use at the original installation site. This warranty is non-transferable.

WHAT IS COVERED

This warranty covers defects in materials or workmanship in your A. O. Smith product when properly installed, used under normal operating conditions, and maintained according to A. O. Smith guidelines and local plumbing codes.

WARRANTY COVERAGE PERIODS

All warranty coverage periods run from the date of purchase, or 60 days after the date of manufacture if the purchase date cannot be verified.

For a period of FIVE YEARS: A. O. Smith warrants its controller and valve assembly to be free of defects in material and workmanship.

For a period of THREE YEARS: A. O. Smith warrants its UF membrane tank to be free of defects in material and workmanship.

This warranty does not cover any equipment purchased for use in applications in which the product is not suited. It is the responsibility of the buyer to determine if a product is suitable for a particular application.

WHAT A. O. SMITH WILL DO

If a component is found defective during its warranty period, A. O. Smith will repair or replace the defective part at its discretion with an identical part or a comparable part if an identical replacement is not available. The owner is responsible for freight charges from the factory and local dealer service or labor fees. The warranty period for any replacement will run for the balance of the original warranty period.

WHAT A. O. SMITH WILL NOT DO

A. O. Smith will not pay for labor to remove or reinstall parts, shipping damage, water damage resulting from system failure, dealer trip charges, unauthorized service, damage caused by failure to follow installation instructions, or replacement filters, media, or routine maintenance.

WHAT IS NOT COVERED

1. This warranty does not cover: damage caused by accident, misuse, neglect, fire, flood, freezing, or other acts of God, improper installation, alteration, vacuum damage, chemicals, operation outside specifications, cosmetic issues, non-A. O. Smith parts, installation costs, improper plumbing connections, lack of maintenance, use with water that is microbiologically unsafe, loss of use, property damage, incidental or consequential damages, freight, or water damage. A. O. Smith disclaims all implied warranties to the fullest extent permitted by law.
2. Except when specifically prohibited by the applicable state law, the Owner, and not the Manufacturer, shall be liable for and shall pay for all charges for labor or other expenses incurred in the removal, repair or replacement of any component part(s) claimed to be defective or any expense incurred to remedy any defect in the product. Such charges may include, but are not necessarily limited to:
 - a. All freight, shipping, handling and delivery costs of forwarding a new component or replacement part(s) to the owner.
 - b. All costs necessary or incidental in removing the defective component part(s) and installing a new component part(s).
 - c. Any material required to complete, and/or permits required for, installation of a new component or replacement part(s).
 - d. All costs necessary or incidental in returning the defective component part(s) to a location designated by the Manufacturer.
 - e. This warranty provides specific legal rights and limitations, but you may have other rights under applicable state law.

OWNER RESPONSIBILITIES

Owners must install and operate the system per A. O. Smith specifications, comply with local codes, prevent freezing or vacuum damage, operate within pressure/temperature limits, replace media/filters as required, use only approved components, and retain proof of purchase and installation date. Either proof of purchase from an authorized dealer or proof of serial number, along with proof of proper installation, will be required to obtain warranty coverage.

HOW TO OBTAIN SERVICE

If service is required, contact your installation dealer or an authorized A. O. Smith dealer. If unavailable, ship the defective component (freight prepaid) to: **A. O. Smith, 1000 Prospect Ct., Appleton, WI 54914**. A. O. Smith will return repaired or replaced parts freight collect. Registration is not required to be covered by this warranty.

LIMITATION OF REMEDIES

The owner's sole remedy is repair or replacement of defective parts. A. O. Smith is not liable for incidental, consequential, water, or property damages. Some states do not allow such limitations; in such states, these may not apply.

STATE LAW RIGHTS

This warranty provides specific legal rights; additional rights may vary by state.

Quick Reference Guide

GENERAL OPERATION

When the system is operating, one of six displays will be shown:

1. Time of day/gpm
2. Flow rate
3. Vacation mode
4. Capacity remaining
5. Days to a regen
6. Dealer name and phone number

Pressing **NEXT** will toggle between the six choices.

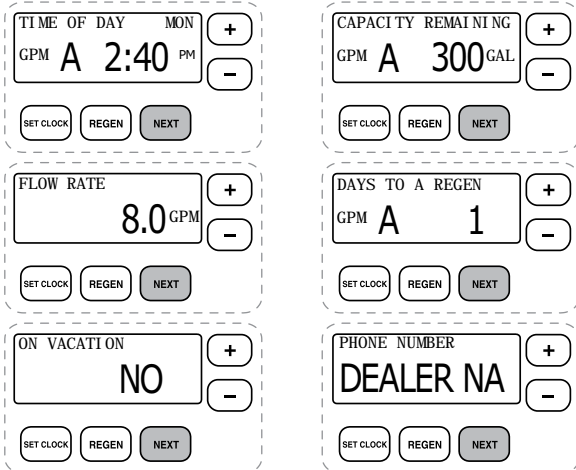

MANUAL REGENERATION

NOTE: For softeners, if brine tank does not contain salt, fill with salt and wait at least two hours before regeneration. If you need to initiate a manual regeneration immediately, press and hold **REGEN** until valve motor starts (typically 3 seconds).

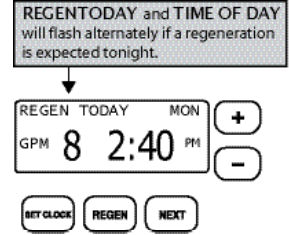

ERROR

If the display toggles between "Error" and an error code (i.e. a number), call a service technician and report the error code.



BYPASS VALVE OPERATION

To shut off water to the system, position arrow handles as shown in the bypass operation diagram below. If your valve doesn't look like the diagram below, contact your service technician for instructions on how to shut off water.

NORMAL OPERATION
"TREATED" WATER EXITS SUPPLY WATER ENTERS

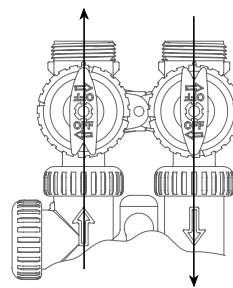

BYPASS OPERATION
SUPPLY WATER EXITS SUPPLY WATER ENTERS

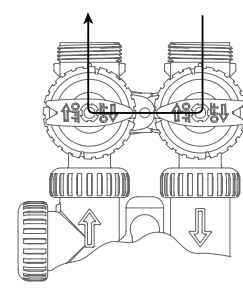

TO SET TIME OF DAY

In the event of a prolonged power outage, time of day flashes, indicating that this needs to be reset. All other information will be stored in memory no matter how long the power outage.

1. Accessed by pressing **CLOCK**
2. Adjust hours with + and - buttons, AM/PM toggles at 12
3. Press **NEXT**
4. Adjust minutes with + and - buttons
5. Press **NEXT**
6. Adjust current day with + and - buttons
7. Press **NEXT** to complete and return to normal operation

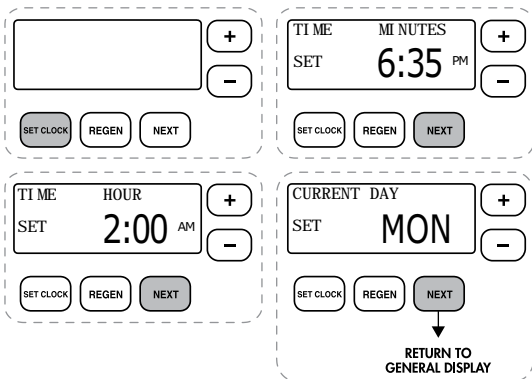

Quick Reference Guide

ADJUST TIME, DAYS BETWEEN REGENERATION, TIME OF REGENERATION AND ALARM BUZZER (Optional)

For initial set-up or to make adjustments, please complete the following steps.

1. Accessed by pressing **NEXT** and + button simultaneously
2. Adjust hardness using + and — buttons
3. Press **NEXT**
4. Adjust days between regenerations using + and — buttons
5. Press **NEXT**
6. Adjust time of regeneration hour with + and — buttons, AM/PM toggles at 12.
7. Press **NEXT**
8. Adjust time of regeneration minutes with + and — buttons
9. Press **NEXT**
10. Turn service alarm time ON with + and — buttons. Default is OFF.
11. Press **NEXT** twice
12. Turn service alarm gallons ON with + and — buttons. Default is OFF.
13. Press **NEXT** twice
14. Turn alarm buzzer ON or OFF with + and — buttons.
15. Press **NEXT**
16. Adjust alarm buzzer start time with + and — buttons.
17. Press **NEXT**
18. Adjust alarm buzzer end time with + and — buttons.
19. Press **NEXT**
20. Turn display backlight ON or OFF with + and — buttons. Default is ON.
21. Press **NEXT** to complete and return to normal operation.

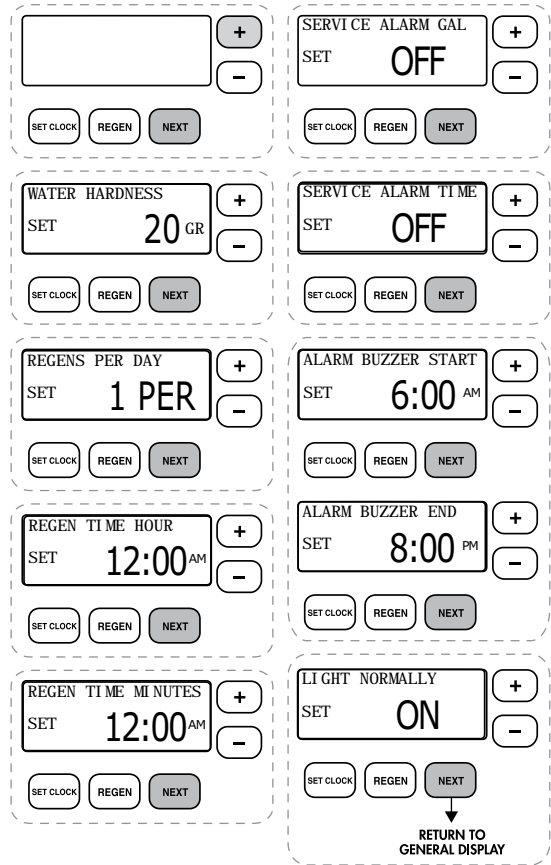

Notes

Notes



1900 Prospect Court • Appleton, WI 54914
Phone: 920-739-9401 • Fax: 920-739-9406

